

Bellari

RP533

Studio Tube Multi-Processor

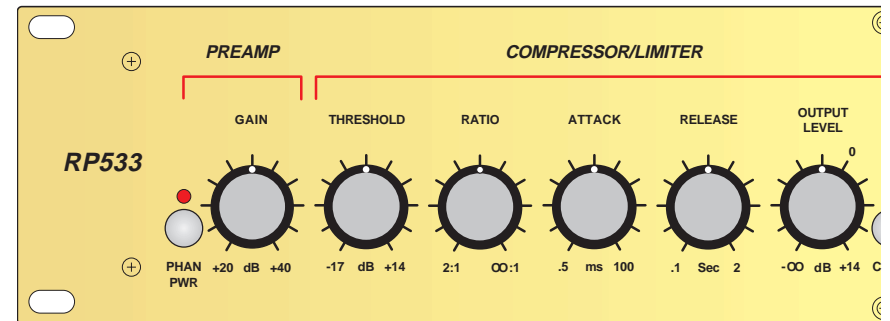

Bellari

Salt Lake City, UT
1/97

OWNERS MANUAL

CONNECTION

Connect a microphone or signal to be processed to the RP533 Input. Press in the Phantom Power switch if your microphone is a condenser or other type that requires phantom power.

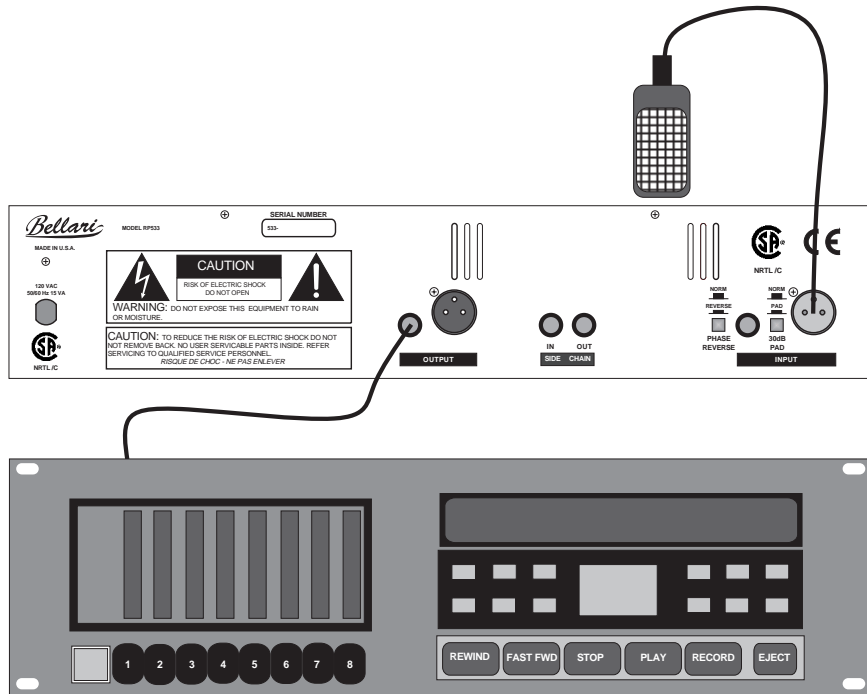

OPERATION

- Apply power to the RP533 and bypass both the Compressor and the Exciter by setting the Comp. Active and Excit. Active switches out.
- Set the Output Level control to 0 dB (about 1 O'Clock).
- Begin checking the microphone or input signal, and adjust the Preamp Gain control until the meter reads approximately 0. If the Gain setting is very low, such as 9 O'Clock or lower, you may wish to press in the 30 dB Pad switch located on the rear panel, then adjust the Gain control for a 0 reading.
- You may now engage and adjust the Compressor and the Sonic Exciter to suit your needs. Please note that the meter will read the gain reduction of the Compressor circuits, or the RP533 overall output level only.

Congratulations and thank you for choosing the Bellari RP533 Studio Tube Multi-Processor. The RP533 is a powerful unit designed for all the signal preamplification and processing required before digital recording. Or, for live applications, the RP533 is ideal for enriching a vocal, fattening up a horn, or giving depth and presence to a piano or guitar. Any application requiring a warm, full-bodied sound can be realized with the RP533.

INSPECTION

1. Unpack and Inspect the RP533 package

Your RP533 was carefully packed at the factory in a protective carton. Nonetheless, be sure to examine the unit and the carton for any signs of damage that may have occurred during shipping. If obvious physical damage is noticed, contact the carrier immediately to make a damage claim. We suggest saving the shipping carton and packing materials for safely transporting the unit in the future.

2. Please complete the Warranty Registration Card and return it to the factory.

BLOCK DIAGRAM

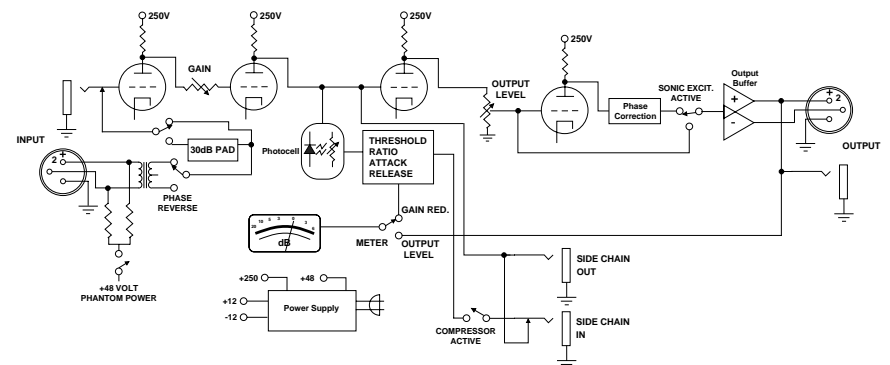

FRONT PANEL DESCRIPTION

Phntm Pwr: When in, applies +48 volts of phantom powering, to the XLR input, for condenser type microphones.

Gain: Adjusts the amount of gain in the tube microphone preamp section. Varies from +13 dB to +33 dB.

Threshold: Sets the level at which the income signal must overcome in order for the RP533 Compressor to begin compressing.

Ratio: The signal to compression ratio - sets the amount of increase in input signal required to raise the output signal 1 dB.

Attack: Varies the amount of time taken for the RP533 to begin compressing once the Threshold level has been reached.

Release: Varies the amount of time taken for the RP533 Compressor to return to normal gain once the signal has dropped below the Threshold level.

Output Level: Varies the overall signal level from the RP533.

Comp. Active Switch: When in, the signal is routed through the Compressor/Limiter section of the RP533.

Excit. Active Switch: When in, the signal is routed through the Sonic Exciter section of the RP533.

Bottom: Adjusts the amount of low frequency process is applied to the signal.

Definition: Adjusts the amount of high frequency process is applied to the signal.

Meter Switch: Switches the signal metering from indicating the output jack level (+4 db Ref.), to indicating the amount of gain reduction of the compressor.

VU Meter: Indicates either the output signal level, or the amount of gain reduction, depending on the position of the Meter Switch.

Power Switch: Turns the RP533 main power on and off.

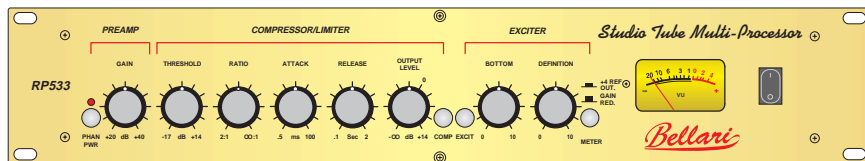

REAR PANEL DESCRIPTION

Outputs: XLR balanced and 1/4" unbalanced connectors for connecting the RP533 to a mixer or other line level input.

Side Chain Input: 1/4" unbalanced jack for receiving incoming signals to directly access the detector circuit of the compressor section.

Side Chain Output: 1/4" unbalanced jack for sending out the signal from the RP533 compressor section. This jack may also be used as a pre-Output Level output.

Note: The Side Chain Input and Output is not an effects loop, it breaks the signal path of the RP533 compressor control circuits.

Input: XLR balanced and 1/4" unbalanced connectors for connecting signals to the RP533.

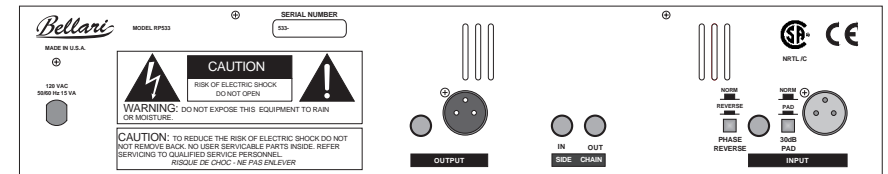

SPECIFICATIONS

Frequency Response	20Hz - 40kHz +/-3dB
Input Impedance	600 Ω balanced 1M Ω unbalanced
THD + Noise	<0.1% typical
Noise Floor	-90 dB
Indicators	Phantom Power LED Analog Meter
Input/Output jacks	XLR balanced 1/4" unbalanced 1/4" unbal. Side Chain
Dimensions	3" x 6" x 19" (180mm X 162mm X 482mm)
Weight	10 lbs. (6 Kg)
Power	120VAC (230VAC) 15VA

TABLE OF CONTENTS

Introduction	1
Inspection	1
Block Diagram	1
Front Panel Description	2
Rear Panel Description	3
Specifications	3
Connection	4
Operation	4
Warranty	5

Check out the complete line of Bellari equipment:

- ADB3 Stereo Tube Direct Box
- MP110 DIRECT DRIVE Mic Preamp
- RP220 Dual Tube Mic Preamp
- RP282a Dual Tube Compressor Limiter

- RP520 Studio Tube Mic Preamp
- RP562 Stereo Tube Sonic Exciter
- RP533 Studio Tube Multi-Processor
- RP583 Studio Tube Compressor/Limiter

LIMITED WARRANTY

This product is warranted to the original consumer purchaser to be free from defects in materials and workmanship under normal installation, use and service for a period of one (1) year from the date of purchase as shown on the purchaser's receipt.

The obligation of Rolls Corporation under this warranty shall be limited to repair or replacement (at our option), during the warranty period of any part which proves defective in material or workmanship under normal installation, use and service, provided the product is returned to Rolls Corporation, TRANSPORTATION CHARGES PREPAID. Products returned to us or to an authorized Service Center must be accompanied by a copy of the purchase receipt. In the absence of such purchase receipt, the warranty period shall be one (1) year from the date of manufacture.

This warranty shall be invalid if the product is damaged as a result of defacement, misuse, abuse, neglect, accident, destruction or alteration of the serial number, improper electrical voltages or currents, repair, alteration or maintenance by any person or party other than our own service facility or an authorized Service Center, or any use violative of instructions furnished by us.

This one-year warranty is in lieu of all expressed warranties, obligations or liabilities. ANY IMPLIED WARRANTIES, OBLIGATIONS, OR LIABILITIES, INCLUDING BUT NOT LIMITED TO THE IMPLIED WARRANTIES OF MERCHANTABILITY AND FITNESS FOR A PARTICULAR PURPOSE, SHALL BE LIMITED IN DURATION TO THE ONE YEAR DURATION OF THIS WRITTEN LIMITED WARRANTY. Some states do not allow limitations on how long an implied warranty lasts, so the above limitation may not apply to you.

IN NO EVENT SHALL WE BE LIABLE FOR ANY SPECIAL, INCIDENTAL OR CONSEQUENTIAL DAMAGES FOR BREACH OF THIS OR ANY OTHER WARRANTY, EXPRESSED OR IMPLIED, WHATSOEVER. Some states do not allow the exclusion or limitation of special, incidental or consequential damages so the above limitation or exclusion may not apply to you. This warranty gives you specific legal rights, and you may also have other rights which vary from state to state.